

# The Next Generation of Switch Valves for Delayed Coking Service

# Refinery Coking

The delayed coker process is a batch process, one of the most hostile environments in the refinery – due to the abrasive and erosive properties of the coke by-product – and crucial to a refinery’s profitability. Valves are cycled frequently and failure can lead to a complete shutdown of a unit, resulting in large process and financial costs. Optimizing valve life-cycle is critical to operational efficiency.

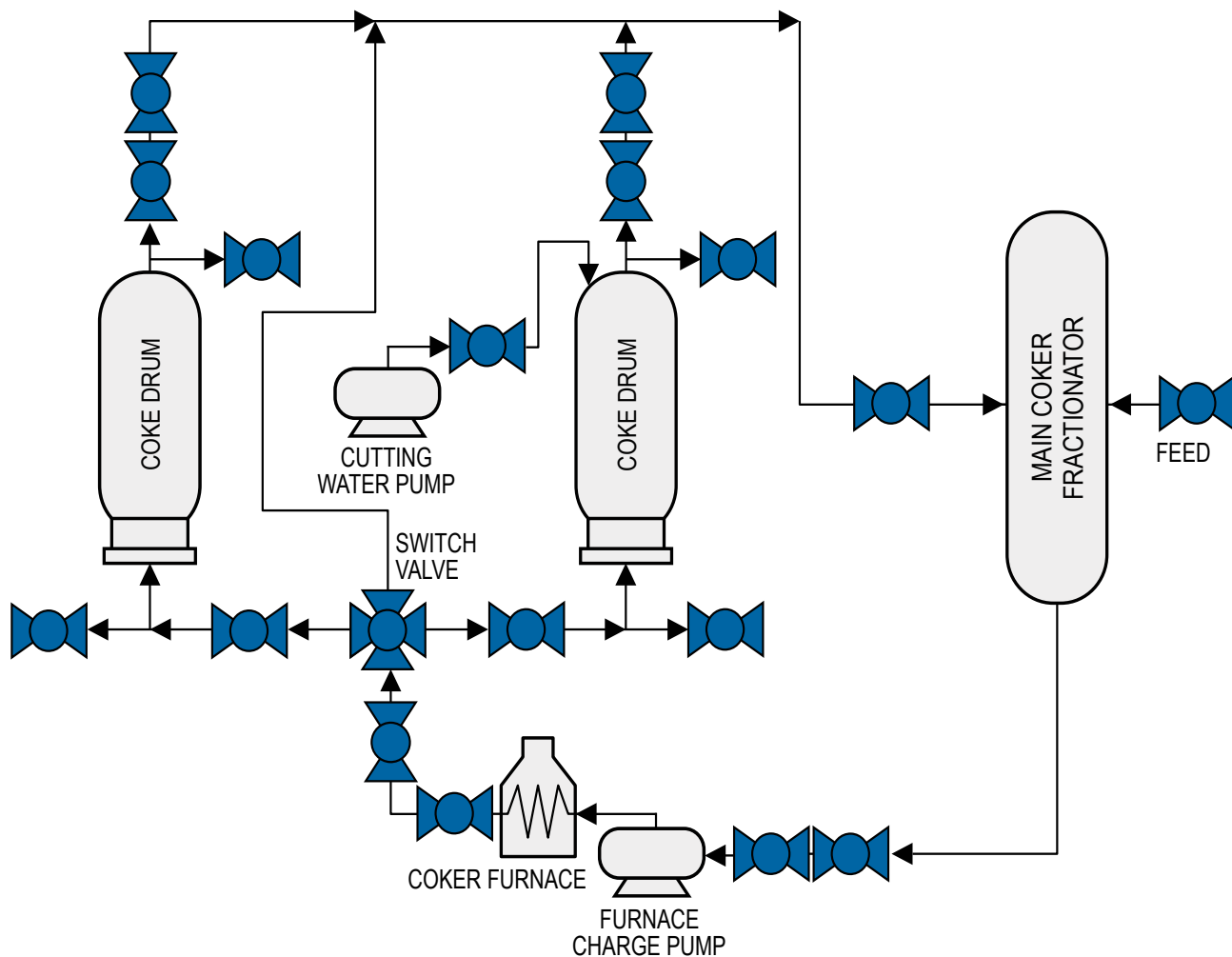

## Improve Availability

The quality of design reduces failure rates and increases reliability.

- High reliability run factors
- Most effective coker valve technology
- Continuous purging design prevents “coking up”
- Lowest life-cycle costs

## Coker Valve Applications:

- Switch valve
- Four-way switch valve
- Drum overhead vapor line
- Feed and withdrawal lines
- Drum blowdown
- Heater isolation
- Cutting water isolation
- Safety relief valves isolation lines
- Drain and vent valves

# Switch Valves for Coking Service

## Switch Valves for Coking Service

Size	8" – 18"
Class	ANSI 9000 & nd ANSI 900 with 600 connections
Material	A217 Gr. C12, F9, 347SS
Stem packing	Belleville®-loaded Grafoil, ISO 15848 Rate "B" Purged lantern rings
Purge connections	Two inlet connections
Option	Flanged connections available

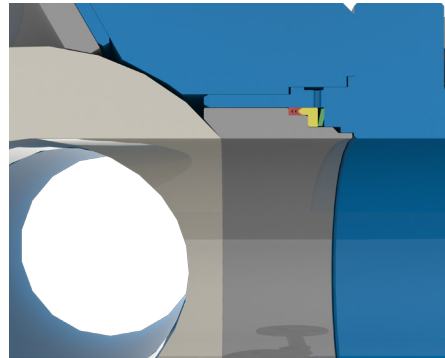
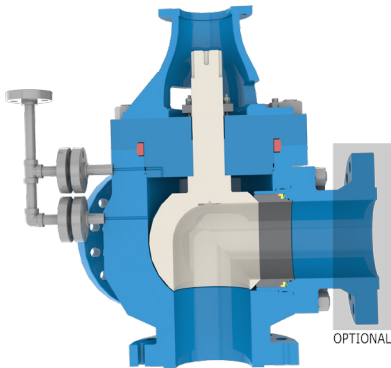

## Coker Switch Valves Key Performance Features and Benefits

Design Features	Detail	Benefits
Belleville® spring loading	<ul style="list-style-type: none"> <li>• Excellent thermal compensation</li> <li>• Prevents coke migration into seat faces</li> <li>• No purge steam needed for seat loading</li> <li>• Eliminates pendulum motion of ball</li> </ul>	<ul style="list-style-type: none"> <li>• Increases reliability</li> <li>• Increases reliability</li> <li>• Lower emissions, enhancing process safety</li> <li>• Inherent fire safety</li> </ul>
Chromium carbide coatings	<ul style="list-style-type: none"> <li>• Ball and seat are HVOF RiTech® spray coated</li> <li>• Extreme wear resistance for cycling and consistent torques</li> <li>• Strong bonding in thermal cycling applications</li> </ul>	<ul style="list-style-type: none"> <li>• Erosion-resistant</li> <li>• Increases cost savings on repair</li> <li>• Longer service life</li> </ul>
Three inlet purges	<ul style="list-style-type: none"> <li>• Proper internal cavity flushing</li> </ul>	<ul style="list-style-type: none"> <li>• Prevents coking up</li> <li>• Reduces maintenance costs</li> </ul>
Spring pocket coke fines protection	<ul style="list-style-type: none"> <li>• Graphite seals in spring pockets protects loading mechanisms in case of steam failure</li> </ul>	<ul style="list-style-type: none"> <li>• Reliability in case of temporary steam loss</li> </ul>

# Refinery Coker Valves



ValvTechnologies, Inc. is a global leader in the design and manufacturing of flow control devices. Founded in 1987 and headquartered in Houston, Texas, ValvTechnologies remains focused on helping customers meet their daily production and process challenges safely and efficiently.

Having built a global reputation for superior quality and dependability across every industry served with products designed to fulfill the requirements of standard applications to the most sophisticated, severe-service processes, ValvTechnologies meets the demands for total flow control solutions, whether one valve at a time, or system-wide.

Bringing together the best people and the latest in technological design and manufacturing processes, ValvTechnologies has created an atmosphere where quality and dependability are built into every product, start to finish.

## Corporate Offices and Manufacturing

### Headquarters & Manufacturing

ValvTechnologies, Inc.  
5904 Bingle Road  
Houston, Texas 77092 U.S.A.  
Telephone +1 713 860 0400  
Fax +1 713 860 0499  
info@valv.com

To locate a distributor or satellite office near you, visit us online at:  
[www.valv.com](http://www.valv.com)

To contact sales anywhere in the world, email [sales@valv.com](mailto:sales@valv.com)

Peru  
Lima  
[peru@valv.com](mailto:peru@valv.com)

Brazil  
São Paulo  
[brazil@valv.com](mailto:brazil@valv.com)

United Kingdom  
Stockton-on-Tees  
[europe@valv.com](mailto:europe@valv.com)

Australia  
Brisbane  
[australia@valv.com](mailto:australia@valv.com)

China  
Shanghai  
[china@valv.com](mailto:china@valv.com)

China  
Chengdu  
[china@valv.com](mailto:china@valv.com)

China  
Beijing  
[china@valv.com](mailto:china@valv.com)

Eastern Europe  
Warsaw  
[poland@valv.com](mailto:poland@valv.com)

Middle East  
Dubai  
[middle.east@valv.com](mailto:middle.east@valv.com)

India  
Chennai  
[india@valv.com](mailto:india@valv.com)

Japan/Korea  
Seoul  
[korea@valv.com](mailto:korea@valv.com)

Spain  
Madrid  
[spain@valv.com](mailto:spain@valv.com)